

VELOBLEND

Advanced Liquid Polymer Activation Technologies

The result of over 30 years pursuing optimum polymer performance and system reliability.



AS IT TURNS OUT, IT IS POSSIBLE TO PATENT “AND”

While the rest of the polymer equipment industry was engaged in a mechanical versus non-mechanical system debate, VeloDyne developed the next generation of advanced polymer activation technologies, a hybrid of the two approaches.

VEL  **DYNE**

A company driven to deliver the very best Polymer Blending, Chemical Feed, and Bulk Solids Handling Systems, fueled by constantly asking, “What If?”



VELOBLEND

Advanced Liquid Polymer Activation Technologies

OPTIMIZING LIQUID POLYMER PERFORMANCE

There have been numerous technologies introduced over the last thirty years designed to activate liquid polymer. The advanced hybrid VeloBlend™ technology has proven to more efficiently induce ultra-high, non-damaging mixing energy, delivering the highest polymer performance over any other technology in the industry.

The VeloBlend is simply the best polymer activation technology ever developed.

—polymer consultant with over 30 years of industry experience

NEAT “AS-SUPPLIED” POLYMER

Neat polymer, as supplied, is primarily comprised of coiled-up polymer, oil, water, and inverting surfactant.



UNACTIVATED POLYMER MOLECULE— CAPABLE OF WITHSTANDING HIGH MIXING ENERGY

In its “neat” (as-supplied) state, the polymer is coiled up like a spring and is capable of withstanding ultra-high mixing energy without damage to its molecular structure.



DAMAGED POLYMER—CAUSED BY EXCESSIVE SHEAR

Once the polymer uncoils, the elongated polymer is now susceptible to damage caused by excessive shear. The result is increased polymer usage, increased polymer cost and reduced process performance.

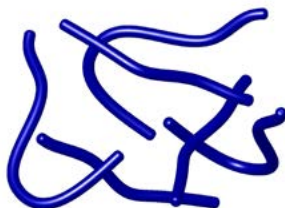

PARTIALLY UNCOILED POLYMER—INSUFFICIENT MIXING ENERGY

If polymer is exposed to insufficient mixing energy, the polymer fails to fully activate with the same negative results in polymer cost and process performance as is seen with damaged polymer.



FULLY ACTIVATED, UNDAMAGED POLYMER— DELIVERING OPTIMAL PERFORMANCE

When neat, coiled-up polymer is properly exposed to ultra-high mixing energy, the oil is effectively “scrubbed” from the polymer, allowing it to become highly activated without damage.



The VeloBlend’s hybrid technology more effectively induces ultra-high, non-damaging mixing energy over the system’s full flow range than any other technology on the market.

EXCLUSIVE HYBRID ACTIVATION TECHNOLOGY

We started by perfecting hydro-dynamic, non-mechanical mixing energy. Born from thirty years of experience, the VeloBlend VH series optimizes the use of non-mechanical mixing energy, exceeding the performance and reliability over existing technologies.

We then eliminated the biggest drawback to non-mechanical blending—its reliance on water pressure. The VeloBlend™ hybrid polymer activation technology combines the reliability of hydro-dynamic, non-mechanical mixing energy with controllable, variable speed hydro-mechanical mixing energy. This process allows for precise control of mixing conditions, allowing optimal performance of any polymer available.

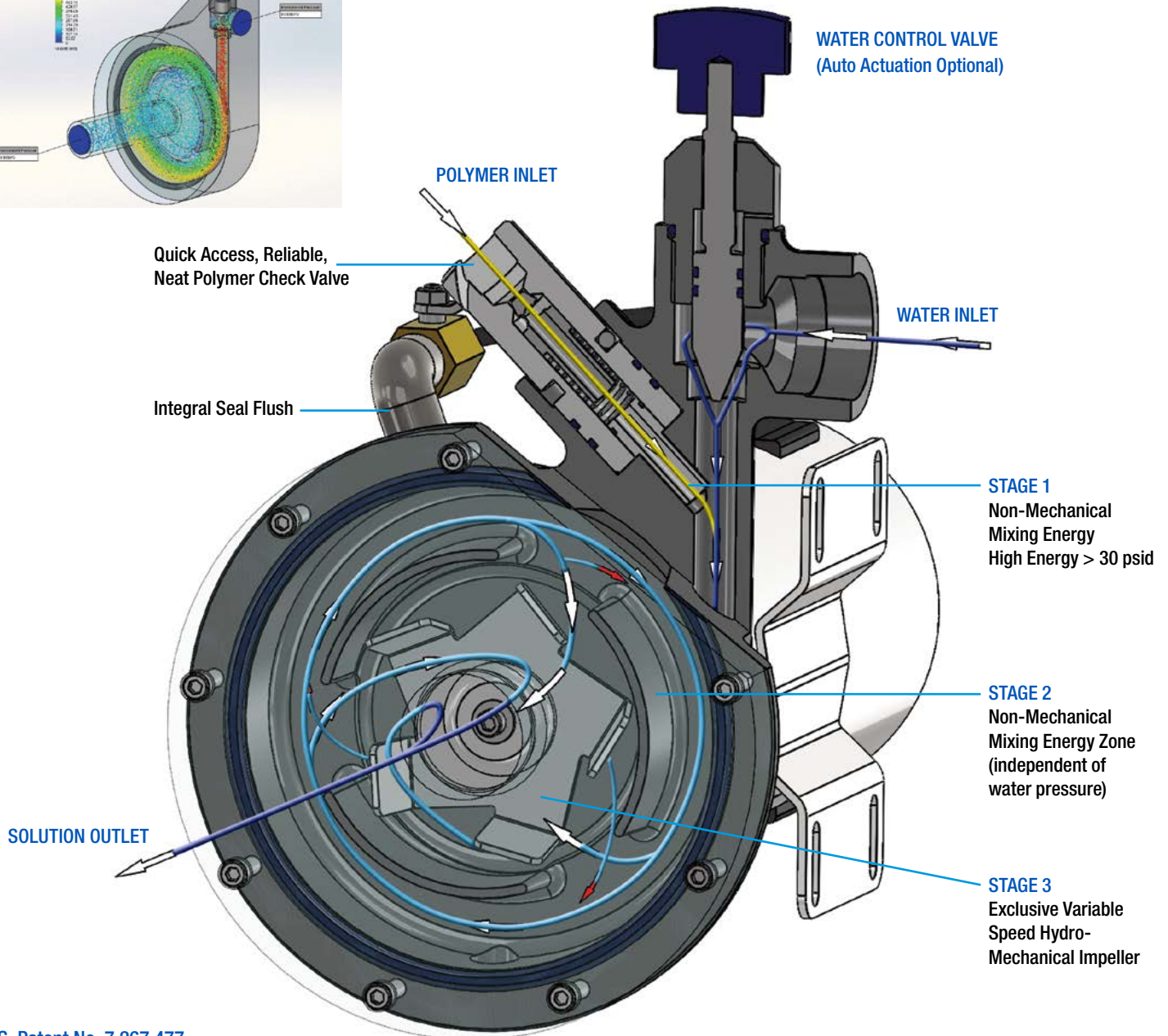
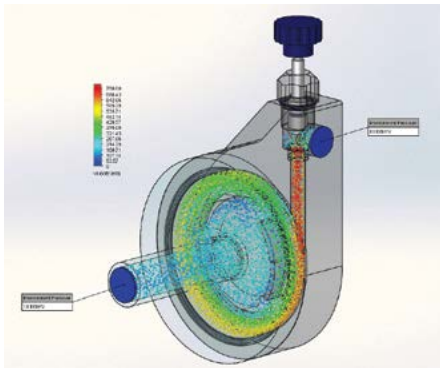

VELOBLEND

Advanced Liquid Polymer Activation Technologies

THE VERSATILE VELOBLEND SYSTEM



1. ACTIVATION CHAMBER

VeloBlend Advanced Liquid Polymer Activation Technology delivers unsurpassed performance and reliability.

2. DILUTION WATER SYSTEM

Up to 600 GPM to meet your application requirements.

3. NEMA 4X CONTROLS

Five standard control systems are available to meet your specific control requirements.

4. NEAT POLYMER PUMP

Progressive cavity pumps standard. Other pump types optional.

5. RUGGED STAINLESS STEEL SKID

Available in 304 or 316 stainless steel. Open design for ease of maintenance. Designed to provide ideal pump suction conditions.

SERIES 6000

- Skid Configuration #2
- Progressive Cavity Pump
- Range: from 0.2 up to 100 GPM Solution
- Control Levels D thru RpSB



SERIES 2400

- Skid Configuration #1
- Progressive Cavity Pump
- Range: from 0.2 up to 50 GPM Solution
- Control Levels D & E



SERIES 12000

- Skid Configuration #3
- Progressive Cavity Pump
- Range: from 10 up to 200 GPM Solution
- Control Levels D thru RpSB



SERIES 36000

- Skid Configuration #4
- Progressive Cavity Pump
- Range: from 40 up to 600 GPM Solution
- Control Levels D thru Rw

Model # Example:
Build Your VeloBlend:

BASE MODEL	CONTROL LEVEL	PLC/HMI OPTION	POWER	SKID SIZE
VM-10P-1200	RpSB	3D	A	2

BASE MODEL:

VELOBLEND BASE MODEL	POLYMER GPH*	WATER GPH**	SKID SIZE BASED ON CONTROL LEVEL (SEE CHART BELOW)				
			D	E	Rw	Rp	RpSB
VM-0.5P-120	0.025 – 0.5	12 – 120	1	E	Rw	Rp	RpSB
VM-2P-300	0.1 – 2	30 – 300					
VM-3P-600	0.15 – 3	60 – 600					
VM-10P-1200	0.5 – 10	120 – 1200					
VM-10P-1800	0.5 – 10	180 – 1800					
VM-15P-2400	0.75 – 15	240 – 2400	2				
VM-30P-6000	1.5 – 30	600 – 6000	3				
VM-60P-12000	3.0 – 60	1200 – 12000	4				
VM-180P-36000	18 – 180	3600 – 36000	4				

*LOWER CAPACITIES AVAILABLE—CONSULT FACTORY **ALTERNATE PUMP/WATER RATE COMBINATIONS AVAILABLE—CONSULT FACTORY *** CAPACITIES SUBJECT TO CHANGE

CONTROL LEVEL:

STANDARD CONTROL OPTIONS	CONTROL LEVELS				
	DISCRETE		PLC		
	D	E	Rw	Rp	RpSB
LOCAL & REMOTE START/STOP DISCRETE INPUT	•	•	•	•	•
4-20mA PUMP PACING ANALOG INPUT	•	•	•	•	•
4-20mA SOLIDS DENSITY ANALOG INPUT					•
SYSTEM RUNNING DISCRETE INPUT	•	•	•	•	•
SYSTEM IN REMOTE DISCRETE INPUT	•	•	•	•	•
PUMP RATE ANALOG OUTPUT		•	•	•	•
SOLUTION RATE ANALOG OUTPUT				•	•
COMMON ALARM DISCRETE INPUT	•	•	•	•	•
MANUAL WATER RATIO CONTROL	SEE PLC/HMI OPTIONS BELOW		•		
AUTO WATER RATIO CONTROL				•	•
SMARTBLEND™ RATIO CONTROL					•
ETHERNET COMMUNICATION				•	•

OTHER CONTROL OPTIONS AVAILABLE—CONSULT FACTORY

PLC/HMI OPTION:

PLC OPTIONS		COLOR TOUCHSCREEN HMI OPTIONS						
		C-MORE		ALLEN BRADLEY			MAGELIS	
		8"	10"	7"	10"	12"	7"	10"
		A	B	C	D	E	F	G
VELODYNE CONTROLLER	1	INTEGRAL 6" COLOR TFT TOUCHSCREEN						
ALLEN BRADLEY MICROLOGIX	2	•	•	•	•	•		
ALLEN BRADLEY COMPACTLOGIX	3	•	•	•	•	•		
MODICON MOMENTUM	4	•	•				•	•

OTHER PLC/HMI OPTIONS AVAILABLE—CONSULT FACTORY

POWER OPTION:

A	120V / 1PH / 60Hz*
B	240V / 1PH / 60Hz
C	240V / 3PH / 60Hz
D	480V / 3PH / 60Hz
E	600V / 3PH / 50Hz

*NOT AVAILABLE FOR 200 GPM WATER AND ABOVE

SKID SIZE:

		WIDTH	DEPTH	HEIGHT
1	CONFIGURATION 1	34"	24"	42"
2	CONFIGURATION 2	34"	30"	72"
3	CONFIGURATION 3	48"	36"	72"
4	CONFIGURATION 4	?	?	?

STANDARD CONSTRUCTION 304SS, AVAILABLE IN 316SS

VELOBLEND

Advanced Liquid Polymer Activation Technologies

VELOBLEND SYSTEM DIMENSIONS

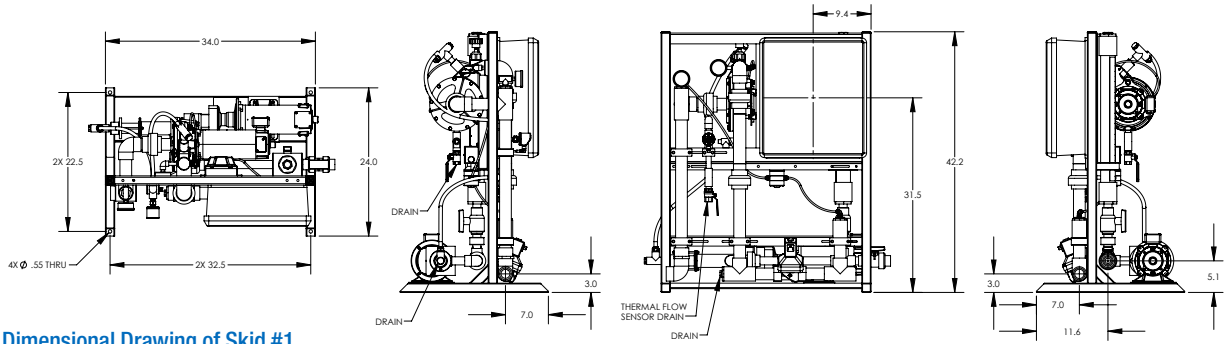

Dimensional Drawing of Skid #1

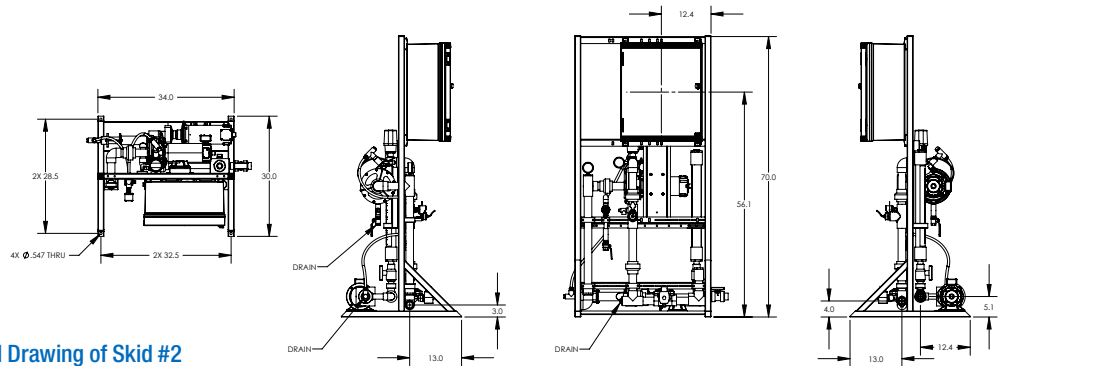

Dimensional Drawing of Skid #2

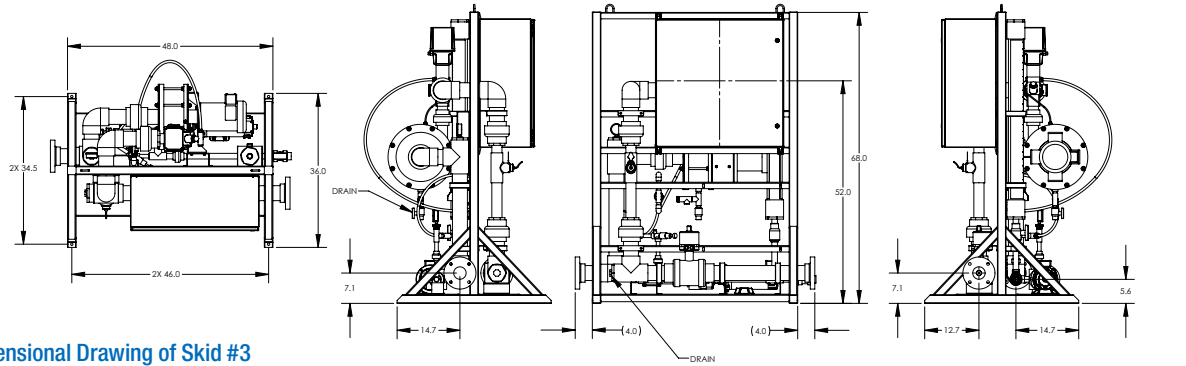

Dimensional Drawing of Skid #3

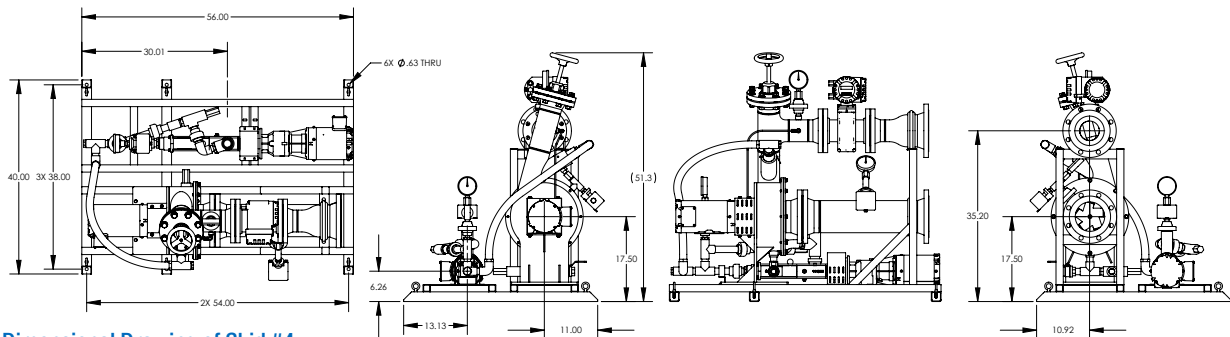

Dimensional Drawing of Skid #4

VELOBLEND HEAVY INDUSTRIAL

The VeloBlend industrial series is designed for the rigors of the pulp & paper, oil & gas, mining, and other demanding industries and applications.

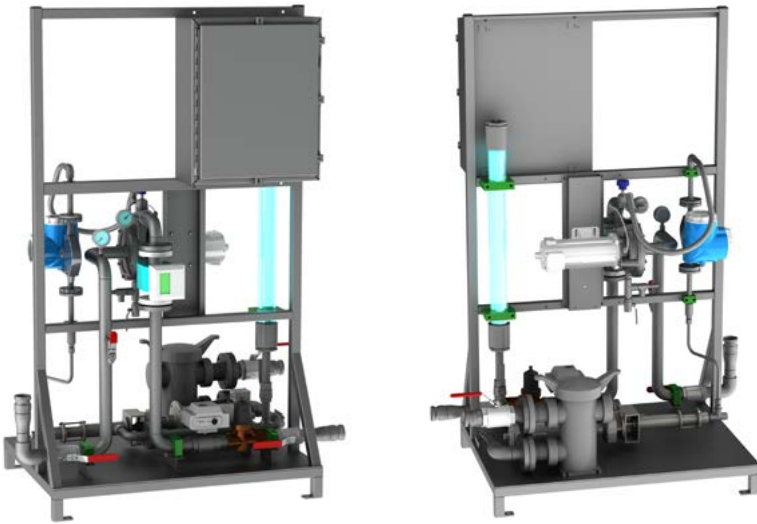

VELOBLEND INDUSTRIAL SERIES FEATURES:

- Ratio control of polymer and water
- VeloBlend Stainless Mixing Chamber
- All stainless steel welded plumbing
- Magnetic flow meter for water flow
- Coriolis mass flow meter for neat polymer
- Skid mounted neat polymer strainer (simplex or duplex available)
- Heavy Duty stainless steel skid

POLYMER PROCESSING PLANTS

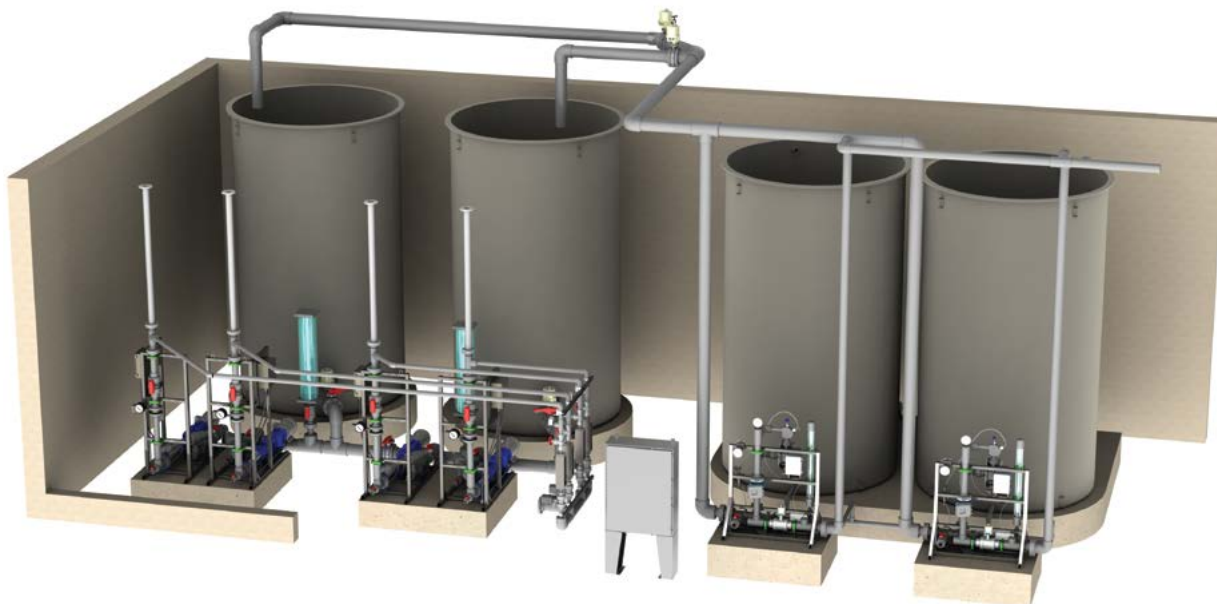



VELODYNE

Advanced Liquid Polymer Activation Technologies

VELODYNE – THREE DECADES OF EXPERIENCE

For over thirty years our team has been dedicated to excellence. Through knowledge gained from thousands of installations worldwide, VeloDyne unites proven technologies with unsurpassed experience. Contact us to learn how our products and services can help optimize your treatment process.

MORE PROVEN SOLUTIONS FROM VELODYNE

Dry Polymer Activation



Auger Feeders & Conveyors



Manual Bag Systems



Liquid Chemical Metering & Feed Systems



Bulk-Bag Systems



Lime Slakers



Containerized Systems



Silo Systems



VeloDyneSystems.com



© 2018 Velocity Dynamics, LLC. All rights reserved. Results may vary under different operating conditions. Specifications, terms and pricing are subject to change. Please consult your local sales representative for details. VeloDyne.1014.0918

Phone: 303-530-3298
E-Mail: Sales@VeloDyneSystems.com